

Capacitive Level Detector For Plastic & Rubber Thermoplastic Polyester Housing Types CA, M30, M32, DC, Self-Teach

TRIPLESHIELD™

CARLO GAVAZZI



- Designed for plastic and rubber applications
- For dry bulk material detection
- Featuring **TRIPLESHIELD™** Sensor Protection
- Self-Teach of sensing distance or remote adjustment by means of wire
- Withstands up to 120°C on the sensing surface
- Automatic detection of NPN or PNP load
- Selectable make or break switching by means of remote function
- Protection: Short-circuit, transients and reverse polarity
- Humidity compensation
- 5-years warranty

Product Description

Capacitive level detector with specialised and optimised features for level detection in plastic and rubber applications. The sensor will adapt automatically to the application when power-on for the first time. The adjustment is easy to change by means of the

remote teach-in function. The sensor front can withstand temperatures up to 120°C. 4-wire DC output with selectable make (NO) or break (NC) switching. Grey polyester housing with 2 m PVC cable or M12 plug (Only M30).

Ordering Key

CA30CLN25BPM1

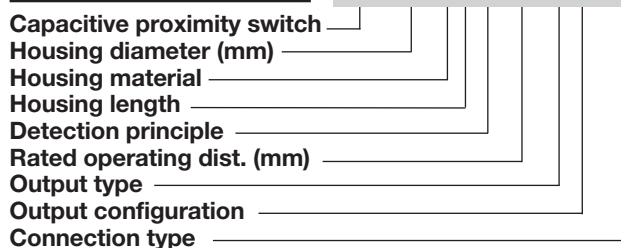

Type Selection

Housing diameter	Ordering no. Cable	Ordering no. Plug
M30	CA30CLN25BP	CA30CLN25BPM1
M32	CA32CLN25BP	

Specifications

Sensitivity	Adjustable (Self-Teach)	Environment	
Repeat accuracy (R)	≤ 5%	Degree of protection	IP 68
Hysteresis (H)	5 - 10%	Operating temperature	-20° to +85°C (-4° to +185°F)
Rated operational volt. (U_B)	10 to 40 VDC (ripple incl.)	Max. temperature on sensing face	120°C (248°F)
Ripple	≤ 10%	Storage temperature	-40° to +85°C (-40° to +185°F)
Rated operational current (I_o)	≤ 250 mA (continuous)	Housing material	
No-load supply current (I_o)	≤ 12 mA	Body	Grey, thermoplastic polyester
Voltage drop (U_d)	≤ 2.5 VDC @ max. load	Cable end	Polyester, softened
Protection	Short-circuit, reverse polarity, transients	Nuts	Black, PA12 Grilamid
TRIPLESHIELD™ protection-EMC		Connection	
IEC 1000-4-2/EN 61000-4-2	30 kV	Cable	M30
IEC 1000-4-3/EN 61000-4-3	> 15 V/m		M32
IEC 1000-4-4/EN 61000-4-4	4 kV	Plug (M1)	Grey, 2 m, 4 x 0.34 mm ²
IEC 1000-4-6/EN 61000-4-6	> 10 V _{rms}	Cable for plug (M1)	Grey, 2 m, 4 x 0.75 mm ²
Frequency of operating cycles (f)	5 Hz		Oil proof, PVC
Indication		Weight	M12 x 1
For output ON	LED, yellow	Cable version - M30 / M32	CON.14NF.. -series
For calibration	LED, red	Plug version - M 30	150 g/230 g
		Approvals	70 g
		CE-marking	UL, CSA
			Yes



Wiring Diagram

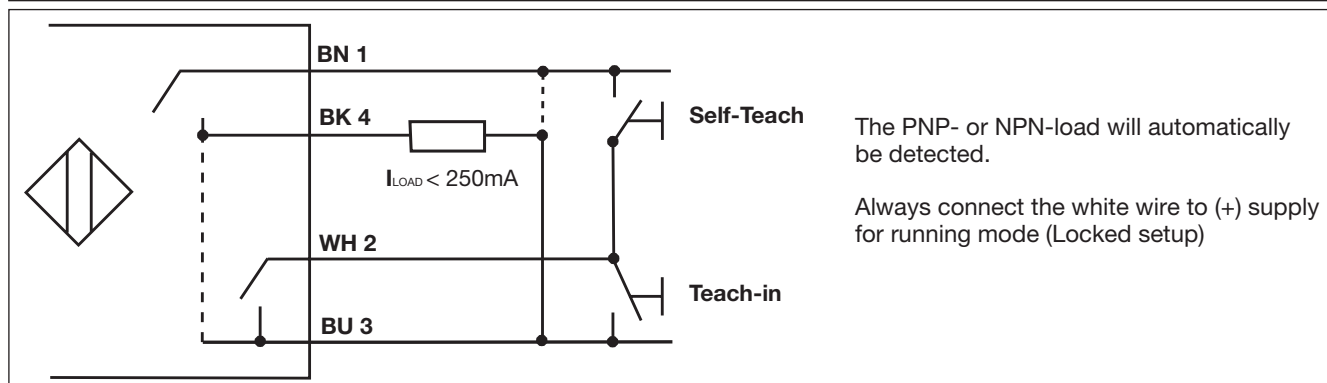

Self-Teach
The PNP- or NPN-load will automatically be detected.
Always connect the white wire to (+) supply for running mode (Locked setup)

Installation

First time calibration

Install and wire the sensor according to the above wiring diagram. Remember to connect the white wire, the 4th wire, to (+) supply
The very first time the sensor is powered up, the sensor will automatically adapt to the surroundings and calculate an

optimal sensitivity by itself – no matter what kind of plastic material to be detected.
As long as the white wire is connected to (+) supply, the sensor will be locked and be in running mode.

New	Action	Description of sensor setup
First-time calibration	New sensor	Factory settings
	Install the sensor in the application	-
	Connect the sensor electrical. White wire to (+) supply	-
	Power ON	Self-Teach: Red LED blinking The sensor is now in running mode

Locked sensor set-up

No other adjustment is needed. As long as the white wire is connected to (+) supply, the set-up of the sensor is locked, and will not change during another power down/up.

Locked	Action	Description of sensor setup
	Sensor running	Last setup
	Power OFF	-
	Power ON (Start-up delay 600ms)	No Self-Teach. The sensor is now in running mode

Recalibration of the sensor

If needed, a new Self-Teach can be activated by disconnecting the white wire from (+) supply, and then connect it again to (+) supply.

You have now activated a new Self-Teach and the sensor now be recalibrated and calculate a new sensitivity according to the application. Make sure that the application is empty – no object to detect.

Self-Teach	Action	Description of sensor setup
Force new Self-Teach	Disconnect white wire	-
	Connect white wire to (+) supply	Self-Teach: Red LED blinking. The sensor is now in running mode
	Power OFF	-
	Power ON (Start-up delay 600 ms)	The sensor is still in running mode

Every time the white wire is disconnected from (+) supply, the Self-Teach function will be initiated and take place when it is again connected to (+) supply

Self-Teach	Action	Description of sensor setup
Force new Self-Teach	Power OFF	-
	Disconnect white wire	-
	Power ON (Startup delay 600 ms)	-
	Connect white wire to (+) supply	Self-Teach: Red LED blinking The sensor is now in running mode

Remote teach-in

It is possible to “teach-in” either background or object, like with the CAxxCLL sensors with a normal teach-in function.

Teach-in Background

Teach-in	Action	Description of sensor setup
Remote Teach-in background	Disconnect white wire	-
	Make sure that the application is empty Connect the white wire to (-) supply > 3 sec. Remove the wire during the next 3 seconds.	The red LED will flash once per second Remote teach-in of background
	Connect white wire to (+) supply	Self-Teach: Red LED blinking The sensor is now in running mode

Teach-in Object

Teach-in	Action	Description of sensor setup
Remote Teach-in object	Disconnect white wire	-
	Make sure that the application is with object. Connect the white wire to (-) supply > 6 sec. Remove the wire during the next 3 seconds.	The red LED will flash twice per second Remote teach-in of object
	Connect white wire to (+) supply	The sensor is now in running mode

Teach-in Background and Object

Teach-in	Action	Description of sensor setup
Remote Teach-in of background and object	Disconnect white wire	-
	Background: Make sure that the application is empty. Connect the white wire to (-) supply > 3 sec. Remove the wire during the next 3 seconds.	The red LED will flash once per second Remote teach-in of background
	Object: Make sure that the application is with object. Connect the white wire to (-) supply > 6 sec. Remove the wire during the next 3 seconds.	The red LED will flash twice per second Remote Teach-in of object
	Connect white wire to (+) supply	The sensor is now in running mode

Toggle between normally open and normally closed

It is possible to toggle between normally open and normally closed by means of the teach-in function.

Teach-in	Action	Description of sensor setup
Normally open <> Normally closed	Disconnect the white wire	-
	Connect the white wire to (-) supply > 9 sec. Remove the wire during the next 3 seconds.	The red LED will flash three times per second Toggle between NO and NC
	Connect white wire to (+) supply	The sensor is now in running mode



Dimensions

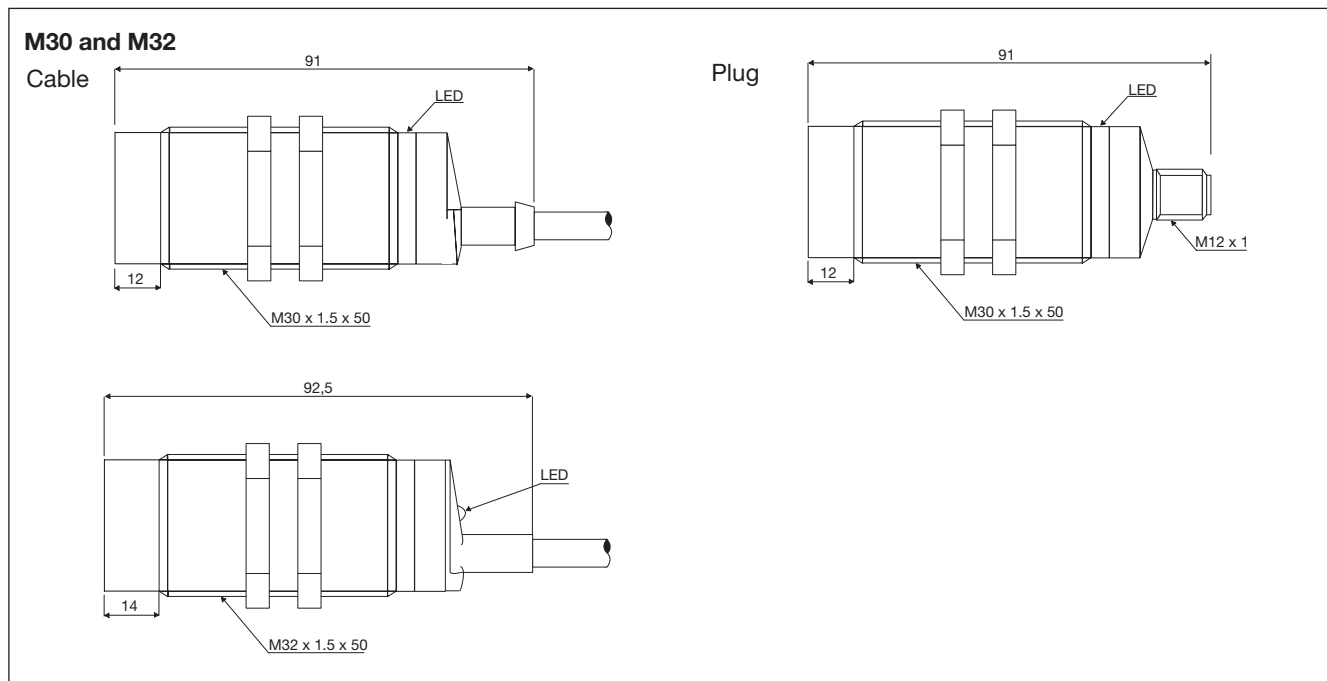

Installation Hints

<p><i>To avoid interference from inductive voltage/current peaks, separate the prox. switch power cables from any other power cables, e.g. motor, contactor or solenoid cables</i></p>	<p><i>Relief of cable strain</i></p> <p>Not correct</p> <p>Correct</p> <p>The cable should not be pulled</p>	<p><i>Protection of the sensing face</i></p> <p>A proximity switch should not serve as mechanical stop</p>	<p><i>Switch mounted on mobile carrier</i></p> <p>Any repetitive flexing of the cable should be avoided</p>
--	--	--	---

Delivery Contents

- Capacitive switch: CA..CLN25BP..
- Manual
- **Packaging:** Cardboard box

Accessories

- Plugs CON.14NF.. series.